

6

5

4

3

2

1

TYPE	OUTPUT		POLE	TIME RATING	VOLTAGE V	Hz	SYN. SPEED R.P.M
	HP.	kW.					
AEEHED	350	261	6	CONT	460	60	1200

TOTALLY ENCLOSED FAN-COOLED VERTICAL SOLID SHAFT TYPE, SQUIRREL CAGE ROTOR

NOTE:

- DIMENSIONS IN INCH
- FRAME NO.5808
- F CLASS INSULATION, S.F.: 1.15
- FOR DIRECT COUPLING.
- BEARING SIZE:
UPPER BEARING: 29330+6028 [INSULATED]
LOWER BEARING: 6320C3 [UNINSULATED]
- UPPER BEARING IS INSULATED. ANY METAL CONNECTIONS TO IT MUST BE INSULATED.
- LUBRICATION:
UPPER BEARING USE OIL.
OIL VISCOSITY: ISO VG68 [300SSU AT 100 °F]
OIL QUANTITY: 6.3 GAL.
LOWER BEARING USE GREASE. [MOBIL POLYREX EM]
- ROTATION: COUNTER-CLOCKWISE [VIEW FROM TOP].
- WITH NON-REVERSE RATCHET MECHANISM.
- APPROXIMATE WEIGHT: 5730
- REED FREQUENCY: 47 HZ
- DOWNTHRUST: 20,200 LBS (L10-8800HRS)
- SPACE HEATER RATED AT 120 VOLT, SINGLE PHASE, 218 WATTS, LEADS TERMINATE IN MAIN LEAD BOX.

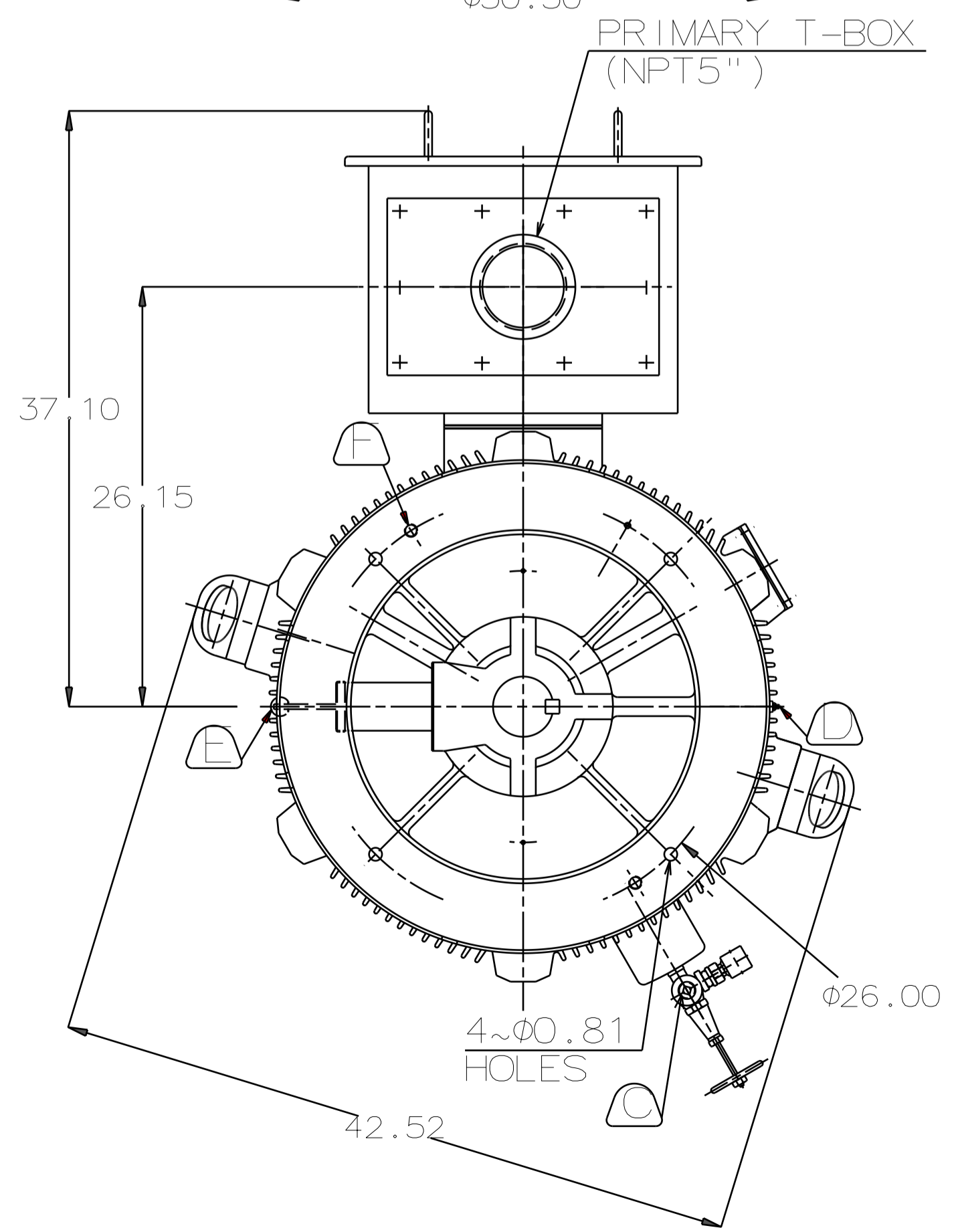
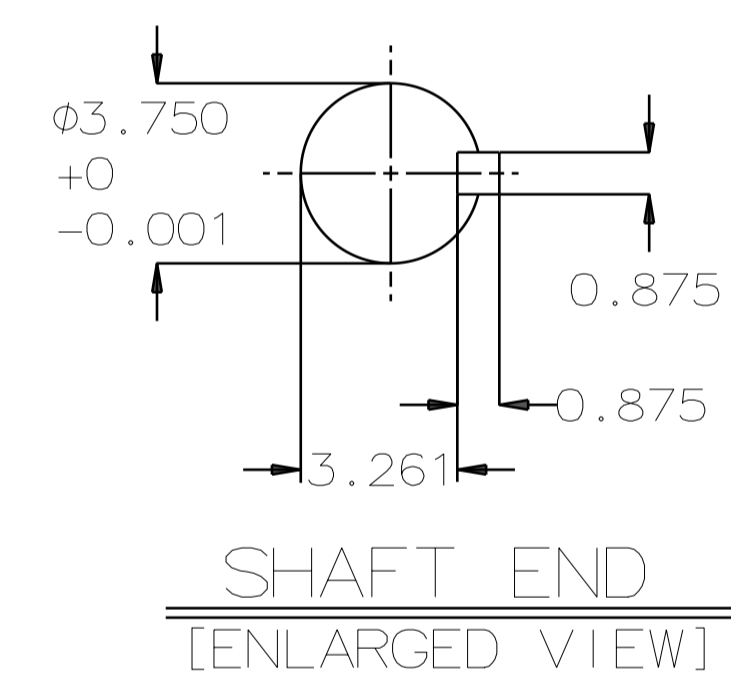
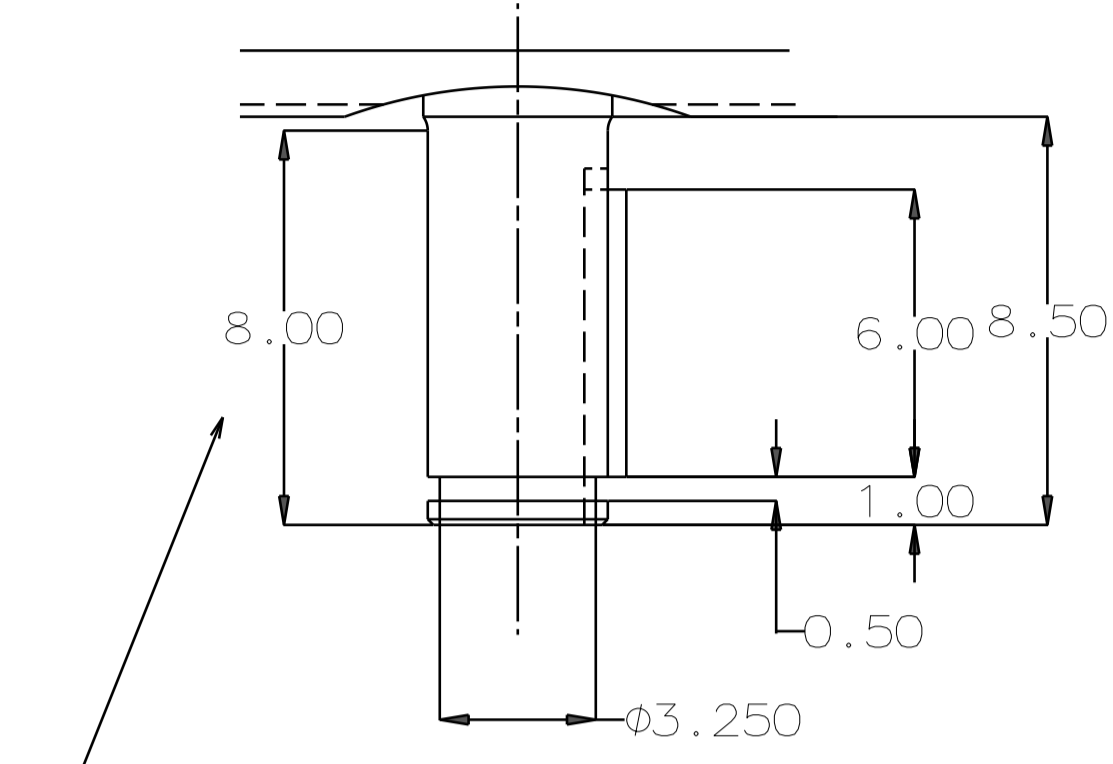
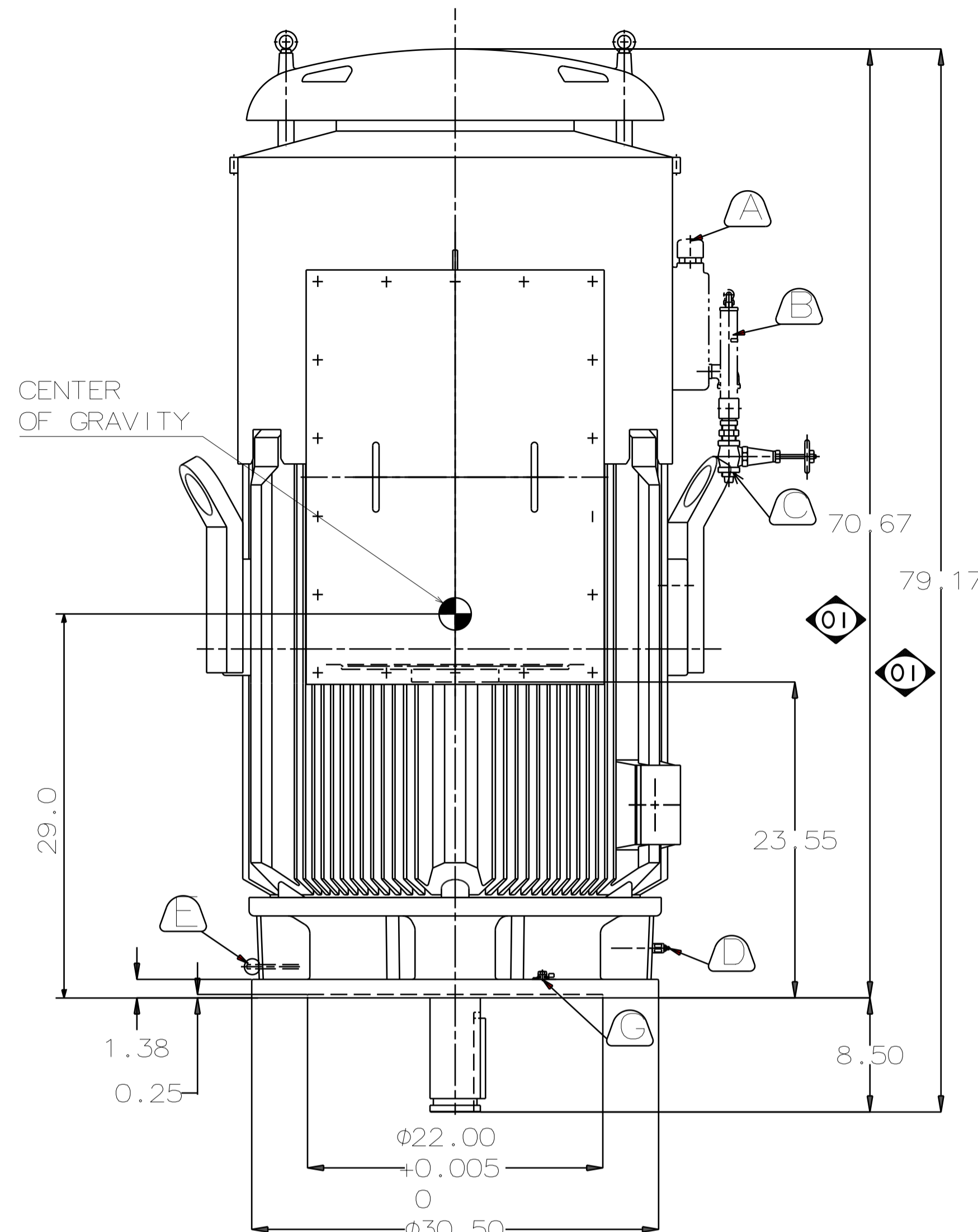

- (A) OIL FILLER [UPPER BEARING]
- (B) OIL GAUGE [UPPER BEARING]
- (C) OIL DRAIN [UPPER BEARING]
- (D) GREASE INLET [LOWER BEARING]
- (E) GREASE DISCHARGER [LOWER BEARING]
- (F) 2~M20 VERTICAL JACKING HOLES, 180°APART IN MOTOR BASE.
- (G) M10 TAPPED HOLE IN MOTOR BASE WITH GROUNDING TERMINAL [R38-10] & BOLT LOCATED AS SHOWN.

DATE	DEC 08 2016	OUTLINE DIMENSIONS	
	VSTP3506	3-PHASE INDUCTION MOTOR	
DWG NO.	4B040L231	REV:01	

DWN.	C.FU	APR.17.2015
CHKD.	R.LEE	APR.17.2015
APPD.	C.LIU	APR.17.2015



6

5

4

3

2

1